

Tool Instruction Engine Lifting Bracket

4328104R2

Tool Number: 12-000-01

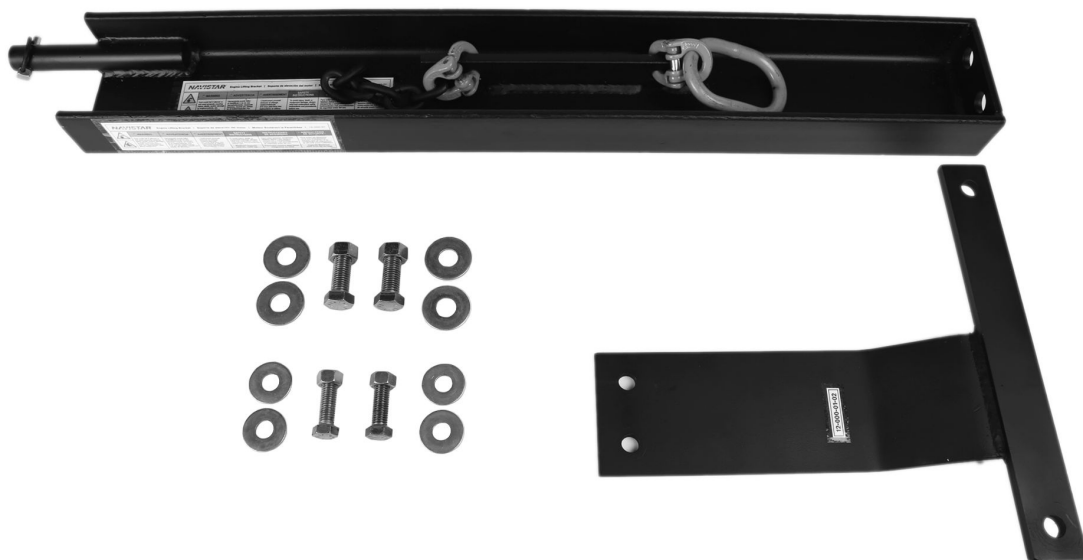

0000048799

Figure 1. Engine Lifting Bracket 12-000-01.

Purpose

The engine lifting bracket is designed to be used to aid in the removal or lifting of the engine, or of the engine and transmission as a single unit.

Application(s)

MaxxForce® 11 and 13 (EPA 10)

MaxxForce® 11 and 13 (EPA 07)

2013 - 2014 Navistar® N13 (EPA 10)

2015 Navistar® N13 (EPA 10)

Application(s) (cont.)



GOVERNMENT REGULATION: Engine fluids (oil, fuel, and coolant) may be a hazard to human health and the environment. Handle all fluids and other contaminated materials (such as filters or rags) in accordance with applicable regulations. Recycle or dispose of engine fluids, filters, and other contaminated materials according to applicable regulations.



WARNING: To prevent personal injury and / or death, read all safety instructions in the “Safety Information” section of the *Engine Service Manual* or *Engine Diagnostic Manual* .



WARNING: To prevent property damage, personal injury, and / or death, park vehicle on hard flat surface, turn the engine off, set the parking brake, and install wheel chocks to prevent the vehicle from moving in either direction.



WARNING: To prevent personal injury and / or death, always wear safe eye protection when performing vehicle maintenance.





Tool Contents

Table 1 Tool Information

Image	Tool Number	Qty	Description
 <p>0000048807</p>	12-000-01-01	1	Main Engine Lifting Bracket
 <p>0000048806</p>	12-000-01-02	1	Adapter Bracket
 <p>0000048805</p>	12-000-01-03	1	Lynch Pin



Tool Contents (cont.)

Table 1. Tool Information (cont.)

Image	Tool Number	Qty	Description
 <p>0000048804</p>	12-000-01-04	1	Hardware Kit
 <p>0000048808</p>	12-000-01-05	1	Rear Lifting Ring
 <p>0000052568</p>	12-000-01-06	1	Cab Shim Assembly
 <p>0000048809</p>	12-000-01-07	1	Lifting Chain Assembly
 <p>0000373344</p>	12-000-01-08 (Not Available In Kit. Purchase Separately)	1	Dust Cover

Tool Contents (cont.)

Table 1. Tool Information (cont.)

Image	Tool Number	Qty	Description
 <p>0000373345</p>	12-000-01-08B (Not Available In Kit. Purchase Separately)	1	Dust Cover Hardware Kit (Contains Thumbscrew, 6 total)
 <p>0000160075</p>	4328104R2	1	Instruction Sheet

Instructions

PRE-INSTALLATION INSPECTION

1. Bring vehicle into shop and park on flat surface.
2. Shift transmission to Park or Neutral and set parking brake.
3. Install wheel chocks.
4. Remove hood. If necessary, remove front bumper.

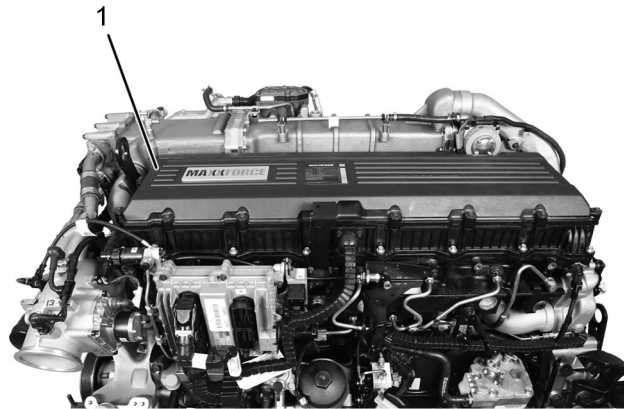

0000370662

Figure 2. Composite Valve Cover.

1. Composite valve cover

Instructions (cont.)

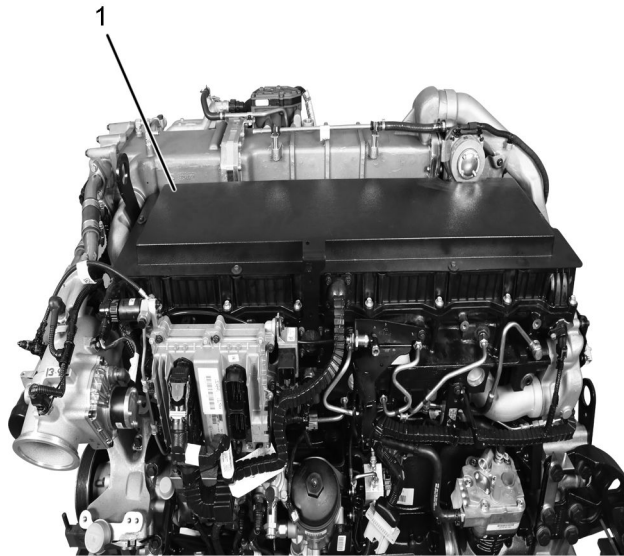

0000370663

Figure 3. Dust Cover 12-000-01-08.

1. Dust cover

CAUTION: To prevent engine / component damage, **ALWAYS** remove composite valve cover and install dust cover prior to installing engine lifting bracket. **NEVER** attempt to lift / hoist an engine with only a composite valve cover installed.

CAUTION: To prevent engine / component damage, thoroughly clean the area above and around the valve cover before removing the upper valve cover to prevent debris / foreign material from contaminating the internal engine components.

CAUTION: To prevent engine / component damage, do not use power tools to remove or install valve cover bolts. The threads will be damaged if a bolt or nut is rotated too quickly.

5. Prior to installation, inspect engine valve cover:
 - If a composite valve cover exists (Figure 2, Item 1), remove valve cover and install Dust Cover 12-000-01-08 (Figure 3, Item 1). Refer to appropriate service manual, service bulletin, or equivalent for detailed instruction.
 - If aluminum valve cover is present, proceed to TOOL INSTALLATION section.

Instructions (cont.)

TOOL INSTALLATION

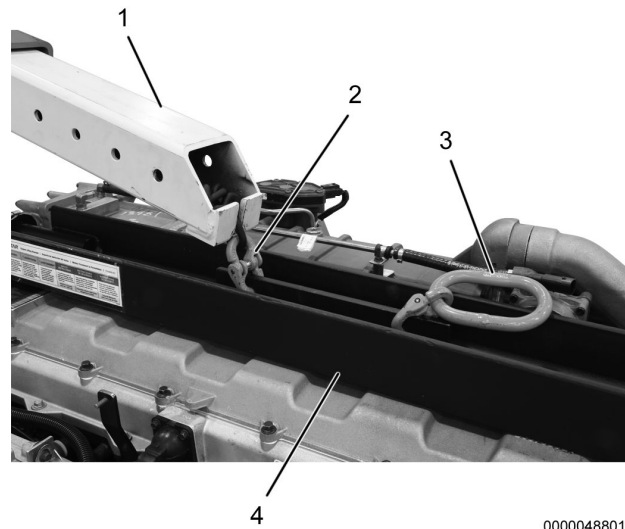

Figure 4. Engine Lift.

1. Engine lift
 2. 12-000-01-07 Lifting Chain Assembly
 3. 12-000-01-05 Rear Lifting Ring
 4. 12-000-01-01 Main Engine Lifting Bracket
-
1. Prepare engine or engine / transmission combination for lifting. Refer to appropriate service manual, service bulletin, or equivalent for detailed instruction.
 2. Position engine lifting bracket (Figure 4, Item 4) on engine.
 3. Connect lifting chain assembly (Figure 4, Item 2) to engine lift (Figure 4, Item 1) using chain link closest to lifting ring.
 4. Connect lifting chain assembly (Figure 4, Item 2) on main engine lifting bracket (Figure 4, Item 4) for engine lifting only, or connect at rear lifting ring (Figure 4, Item 3) for lifting of engine and transmission as single assembly.

Instructions (cont.)

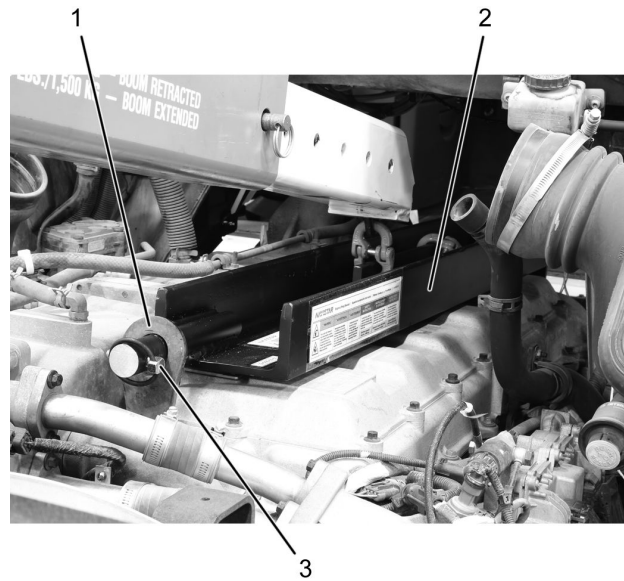

Figure 5. Engine Lifting Bracket 12-000-01-01.

1. Front engine lifting eyelet
 2. Main engine lifting bracket
 3. 12-000-01-03 Lynch Pin
-
5. Position main engine lifting bracket (Figure 5, Item 2) through front engine lifting eyelet (Figure 5, Item 1) and secure with lynch pin (Figure 5, Item 3).

Instructions (cont.)

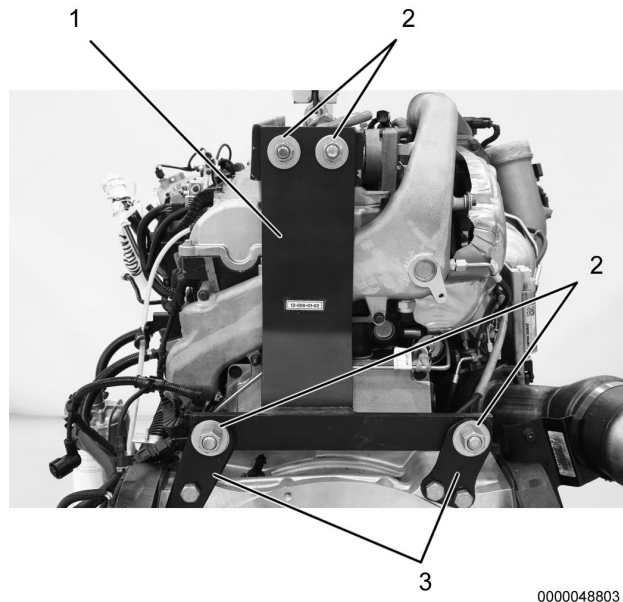

Figure 6. Adapter Bracket 12-000-01-02.

1. Adapter bracket
2. Bolt and nut (4)
3. Rear lifting eyelet (2)

NOTE: Adapter bracket bolts are installed loosely to allow for bracket movement.

NOTE: For vehicles equipped with Navistar® N13 engines, it is necessary to remove / reposition the NOx sensor mounting plate prior to installing adapter bracket.

6. Install Adapter Bracket 12-000-01-02:

- For MaxxForce® engines, install adapter bracket (Figure 6, Item 1) to front side of rear lifting eyelets (Figure 6, Item 3) on bell housing and main bracket. Secure with four bolts and nuts (Figure 6, Item 2). Install all bolts loosely.
- For N13 engines, install adapter bracket to rear side of rear lifting eyelets on bell housing and main bracket. Secure with four bolts and nuts. Install all bolts loosely.

Instructions (cont.)

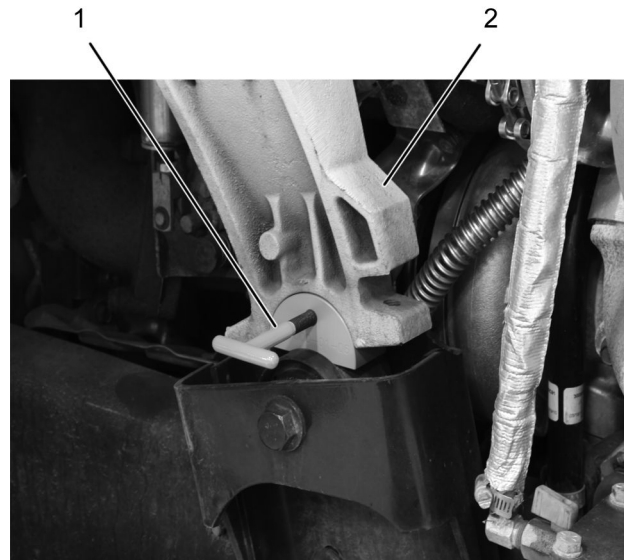

0000052581

Figure 7. Cab Shim Assembly 12-000-01-06.

1. Cab shim assembly
2. Cab

NOTE: Cab shim assembly is not required for all models, although it may provide additional access for some models.

7. To use cab shim assembly:
 - Remove steel strap securing cab mount to cab bushing.
 - Safely raise passenger side of cab.
 - Install cab shim assembly (Figure 7, Item 1).
 - Lower cab (Figure 7, Item 2) on cab shim assembly.
8. Lift engine or engine / transmission combination. Refer to appropriate service manual, service bulletin, or equivalent for detailed instruction.

Instructions (cont.)

TOOL REMOVAL

⚠ WARNING: To prevent property / engine / vehicle damage, personal injury and / or death, make sure engine is properly secured prior to removing the lift chain.

1. If required, lower and secure engine or engine / transmission combination. Refer to appropriate service manual, service bulletin, or equivalent for detailed instruction.
2. If using a cab shim assembly:
 - Safely raise passenger side of cab.
 - Remove cab shim assembly (Figure 7, Item 1).
 - Lower cab.
 - Install steel strap securing cab mount to cab bushing.
3. Remove adapter bracket (Figure 6, Item 1) from front side of rear lifting eyelets (Figure 6, Item 3) on bell housing and main bracket.
4. Remove lynch pin (Figure 5, Item 3).
5. Remove main engine lifting bracket (Figure 5, Item 2) from front engine lifting eyelet (Figure 5, Item 1).
6. Remove lifting chain assembly (Figure 4, Item 2) from main engine lifting bracket (Figure 4, Item 4), and if necessary, rear lifting ring (Figure 4, Item 3).
7. If necessary, continue to prepare engine assembly or engine / transmission assembly combination for installation. Refer to appropriate service manual, service bulletin, or equivalent for detailed instruction.

CAUTION: To prevent engine / component damage, thoroughly clean the area above and around the dust cover before removing to prevent debris / foreign material from contaminating the internal engine components.

CAUTION: To prevent engine / component damage, do not use power tools to remove or install valve cover bolts. The threads will be damaged if a bolt or nut is rotated too quickly.

8. If necessary, remove Dust Cover 12-000-01-08 and install composite valve cover. Refer to appropriate service manual, service bulletin, or equivalent for detailed instruction.
9. Install hood. If necessary, install front bumper.
10. Remove wheel chocks.

Contact Information

If you would like to order additional tools or need replacement parts, please refer to the Navistar Service Tool Catalog. If you have questions, concerns, or feedback, please contact Navistar Service Tool Support Center:

- Submit a Service Tool iKNow Case File.
- Phone: 800-365-0088 (toll free).