

Tool Instruction CRANKSHAFT PROTECTOR

4328349R1

Tool Number: 12-075-01

Purpose



0000387977

Figure 1. 12-075-01 Crankshaft Protector.

The 12-075-01 Crankshaft Protector assists with removal of the harmonic balancer. When installed, the crankshaft protector helps to protect the crankshaft threads. It also provides additional support for the pulley when removing it, eliminating a dropped component condition.

Application(s)

2015 PSI 8.8L Engine



GOVERNMENT REGULATION: Engine fluids (oil, fuel, and coolant) may be a hazard to human health and the environment. Handle all fluids and other contaminated materials (such as filters or rags) in accordance with applicable regulations. Recycle or dispose of engine fluids, filters, and other contaminated materials according to applicable regulations.

Application(s) (cont.)

⚠ WARNING: To prevent property damage, personal injury, and / or death, read all safety instructions in the “Safety Information” section of the *Engine Service Manual* or *Engine Diagnostic Manual*.



⚠ WARNING: To prevent property damage, personal injury, and / or death, park vehicle on hard flat surface, turn the engine off, set the parking brake, and install wheel chocks to prevent the vehicle from moving in either direction.

⚠ WARNING: To prevent personal injury or death, allow vehicle to cool before removing components.

⚠ WARNING: To prevent personal injury and / or death, always wear safe eye protection when performing vehicle maintenance.

Tool Contents

Table 1

Image	Tool Number	Qty	Description
 <p>0000387976</p>	12-075-01	1	Crankshaft Protector
 <p>0000160075</p>	4328349R1	1	Tool Instruction

Instructions

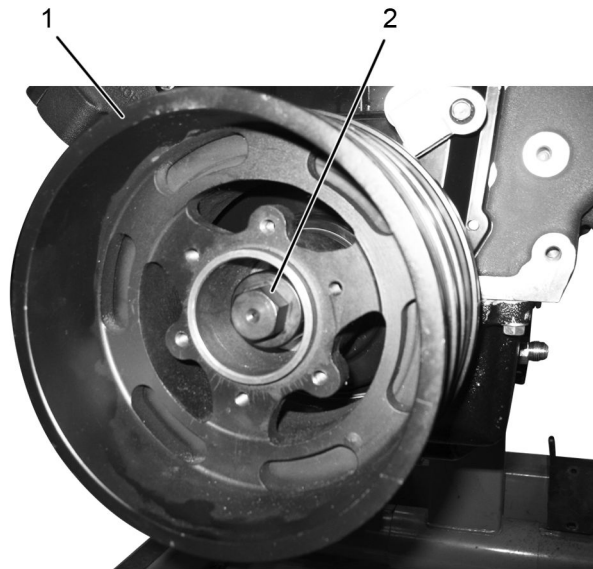

0000387978

Figure 2. Harmonic Balancer.

1. Harmonic balancer
2. Crankshaft protector

NOTE: Some components removed from graphic for clarity.

1. Bring vehicle into shop and park vehicle on flat surface with wheels straight ahead.
2. Shift transmission to Park or Neutral and set parking brake.
3. Install wheel chocks.
4. Access harmonic balancer (Figure 2, Item 1). Refer to appropriate engine service manual, service bulletin, or equivalent for detailed instruction.
5. Install crankshaft protector (Figure 2, Item 2) into the crankshaft end. Hand tighten only.
6. Remove harmonic balancer. Refer to appropriate engine service manual, service bulletin, or equivalent for detailed instruction.

NOTE: The crankshaft protector MUST be removed prior to installing the harmonic balancer.

7. Remove crankshaft protector.
8. Install harmonic balancer. Refer to appropriate engine service manual, service bulletin, or equivalent for detailed instruction.
9. Remove wheel chocks.

Contact Information

If you would like to order additional tools or need replacement parts, please refer to the Navistar Service Tool Catalog. If you have questions, concerns, or feedback, please contact Navistar Service Tool Support Center:

- Submit a Service Tool iKNow Case File.
- Phone: 800-365-0088 (toll free).