

Tool Instruction Load Leveler Adapter Kit

4328856R1

Tool Number: 12-000-07



0000477576

Figure 1. Load Leveler Adapter Kit 12-000-07

Purpose

Essential tool kit used to adapt KL30190 load leveler to engine.

Application(s)

2024 International[®] S13 Integrated Powertrain, 2024 International[®] S13 Engine. Additional vehicle applications may apply.

Application(s) (cont.)



GOVERNMENT REGULATION: Engine fluids (oil, fuel, and coolant) may be a hazard to human health and the environment. Handle all fluids and other contaminated materials (such as filters or rags) in accordance with applicable regulations. Recycle or dispose of engine fluids, filters, and other contaminated materials according to applicable regulations.



WARNING: To prevent personal injury, and / or death, or damage to property, read all safety instructions in the “Safety Information” section of the *Engine Service Manual* or *Engine Diagnostic Manual*.



WARNING: To prevent personal injury, and / or death, or damage to property, park vehicle on hard flat surface, turn the engine off, set the parking brake, and install wheel chocks to prevent the vehicle from moving in either direction.





WARNING: To prevent personal injury and / or death, always wear safe eye protection when performing vehicle maintenance.



WARNING: To prevent personal injury, and / or death, or damage to property, inspect tool for wear / damage prior to use. Replace any worn or damaged components as necessary.

Tool Contents

Table 1

Image	Tool Number	Qty	Description
 <p>0000477575</p>	12-000-07	1	Load Leveler Adapter Kit
 <p>0000160075</p>	4328856R1	1	Tool Instruction

Instructions

IMPORTANT: Please reference International® Service PortalSM regarding any possible revisions to this document.

Instructions (cont.)

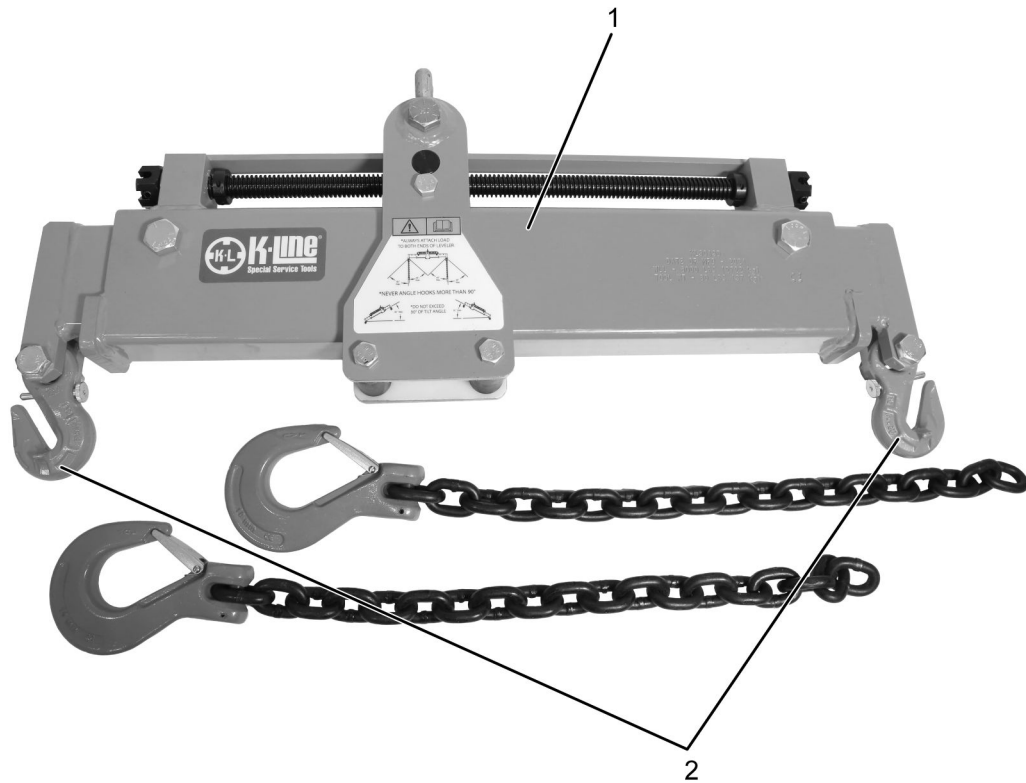

0000478015

Figure 2. Load Leveler KL30190

1. Load Leveler (KL30190)
2. Orange hooks (part of KL30190)

1. To install the tool, remove orange hooks (Figure 2, Item 2) from load leveler (Figure 2, Item 1) and retain.

Instructions (cont.)

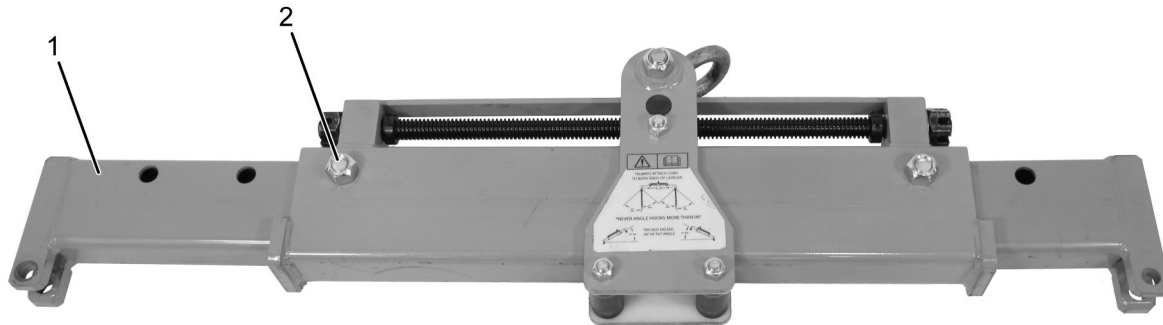

0000478016

Figure 3. Load Leveler KL30190

1. Load leveler arm
 2. Locking hardware
2. Remove locking hardware (Figure 3, Item 2) extend one load leveler arm (Figure 3, Item 1) and reinstall locking hardware (Figure 3, Item 2) into third position.

Instructions (cont.)

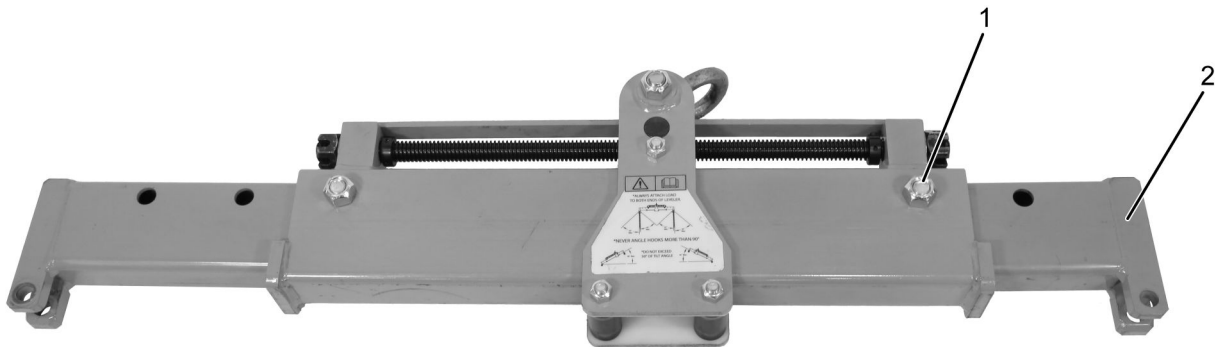

0000478017

Figure 4. Load Leveler KL30190

1. Locking hardware
 2. Load leveler arm
3. Remove locking hardware (Figure 4, Item 1) extend one load leveler arm (Figure 4, Item 2) and reinstall locking hardware (Figure 4, Item 1) into second position.

Instructions (cont.)

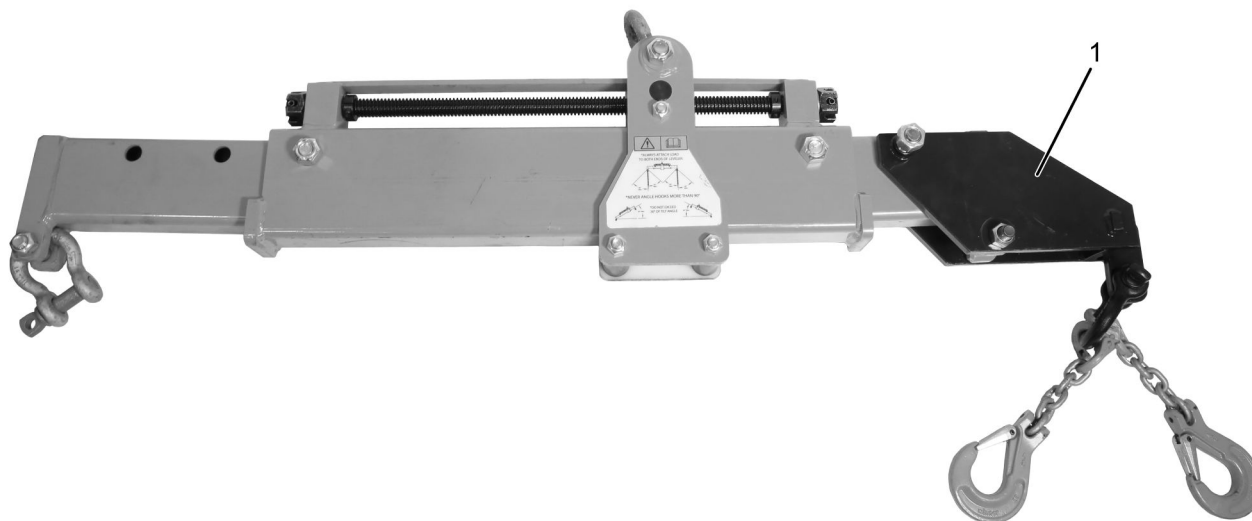

0000478018

Figure 5. Load Leveler Adapter Kit 12-000-07 installed on Load Leveler KL30190

1. Black adapter bracket (part of 12-000-07)
4. Install black adapter bracket (Figure 5, Item 1) to load leveler arm with locking hardware in second position.

Instructions (cont.)

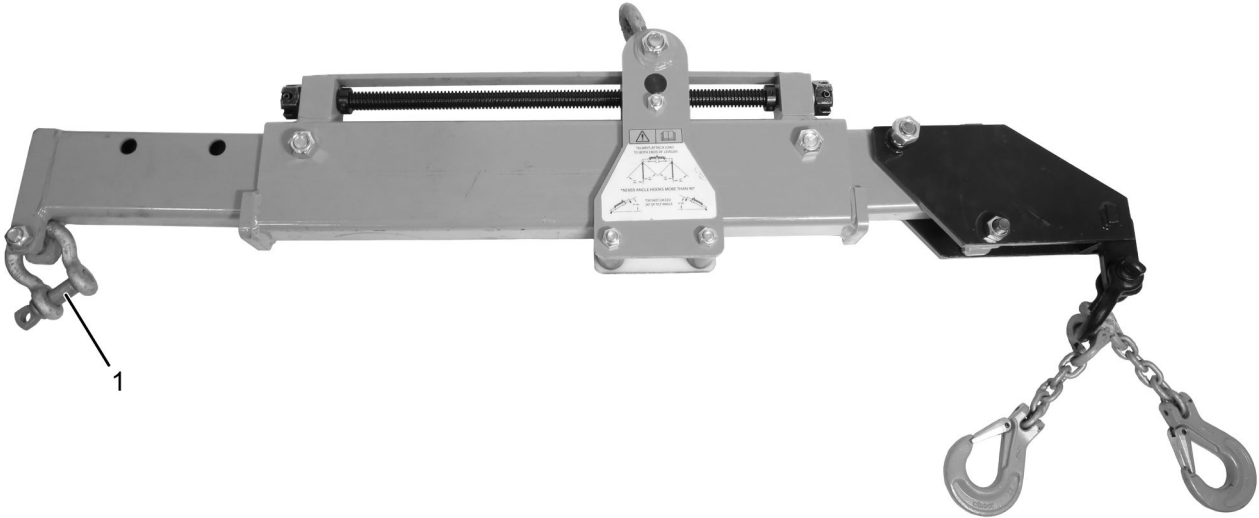

0000478019

Figure 6. Load Leveler Adapter Kit 12-000-07 installed on Load Leveler KL30190

1. Shackle (part of 12-000-07)
5. Install individual shackle (Figure 6, Item 1) to load leveler arm with locking hardware in third position. Ensure threads of shackle face towards center (figure 6, Item 1).

Instructions (cont.)



0000478020

Figure 7. Removing Load Leveler Adapter Kit 12-000-07 from Load Leveler KL30190

1. Black adapter bracket (part of 12-000-07)
 2. Shackle (part of 12-000-07)
6. To remove the tool, remove black adapter bracket (Figure 7, Item 1) and shackle (Figure 7, Item 2) from load leveler and retain.

Instructions (cont.)

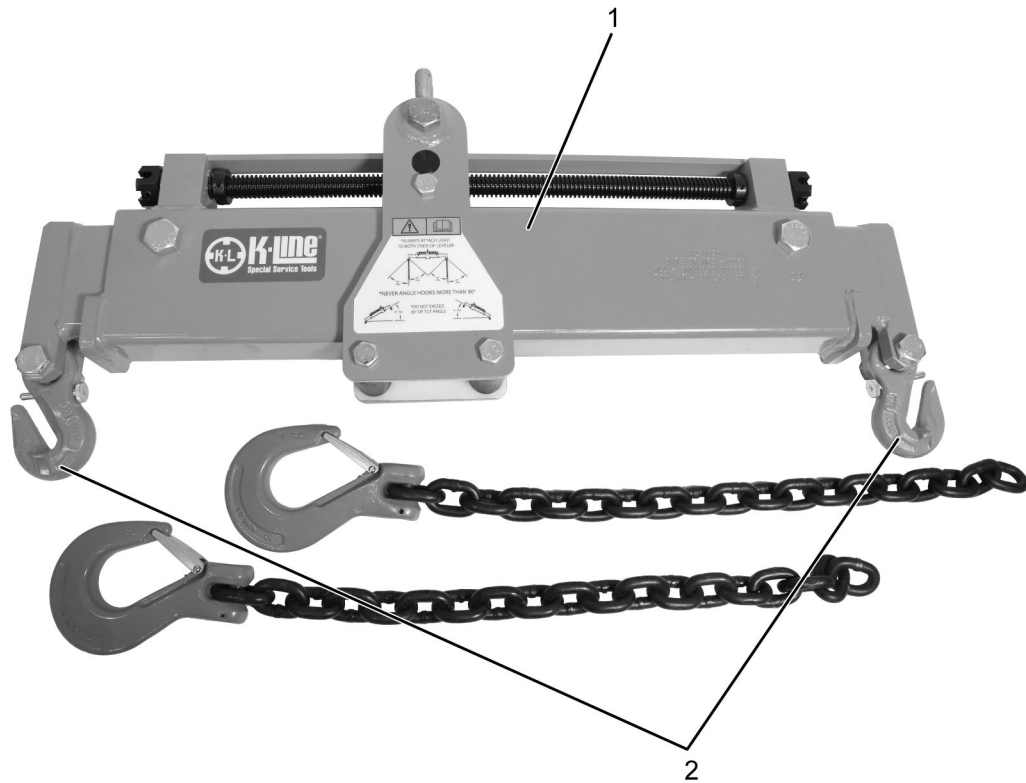

0000478015

Figure 8. Load Leveler KL30190

1. Load Leveler (KL30190)
2. Orange hooks (part of KL30190)

7. Reinstall orange hooks (Figure 8, Item 2) to load leveler (Figure 8, Item 1).

Care and Maintenance

- Keep tools clean and free of contaminants.
- Replace any damaged components.

Contact Information

If you would like to order additional tools or need replacement parts, please refer to the Navistar Service Tool Catalog. If you have questions, concerns, or feedback, please contact Navistar Service Tool Support Center:

- Submit a Service Tool iKNOW Case File.
- Phone: 800-365-0088 (toll free).